



LEGENDS EQUIPMENT

TUBING AND FITTINGS INSTALLATION GUIDE

Tubing and Fittings Installation Guide.

This guide offers general recommends of how to properly install a central vacuum housekeeping system.

These systems are different from water, steam or dust collection duct system. Follow these few basic principals and your system should provide trouble free operation.

- Compression Couplings
- Instalok Coupling
- Top in Drop (Preferred drop method)
- Side in Drops
- Labels
- Zoned System Design
- Elbows
- Eliminate Inclines (Horizontal or Vertical Only)
- Tubing Supports

COMPRESSION COUPLING

IMPORTANT!

INSTALLATION INSTRUCTIONS

IMPORTANT!

HOLDING THE COUPLING PROPERLY

- To avoid slippage of the gasket, sleeve and gasket protector (when used), always hold coupling as shown in Figure 1.
- Couplings are shipped in ready-to-use condition and should not be disassembled.

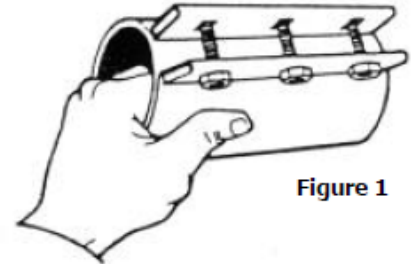

Figure 1

PREPARING FOR INSTALLATION

- Check code number for OD of pipe or tube you intend to join. Coupling has been factory-sized and inspected before shipping.
- Clean outside of tube to make it free of dirt and grease which can cause coupling slippage.
- Make sure tube is free of jagged ends and external burrs which could cut gaskets.
- Make sure outside surface of tube is dry.
- Make sure sleeve and gasket partings are in opposed positions (Figure 2).
- Be sure gasket teeth (and gasket protector teeth) mesh and do not overlap.

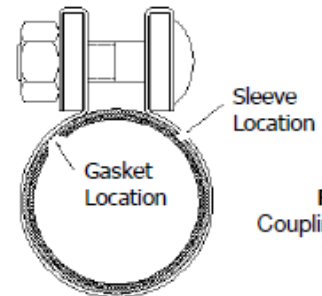

Figure 2
Coupling Ready to Install

ASSEMBLING TUBE AND COUPLING

- Slide coupling over one tube until end of that tube is exposed.
- Butt tube ends (Figure 3).
- Slide coupling back until it is centered over point where tubes are butted. Use care to avoid wrinkling, or overlapping gasket or gasket protector.
- When the potential for static build-up exists, a grounding strip *must be used*.

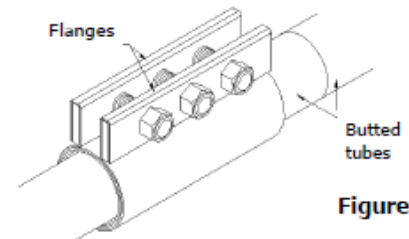

Figure 3

TIGHTENING THE COUPLING

- To assure proper seating of inner sleeve and gasket, partially tighten bolts in a uniform manner.
- Tighten bolts evenly to torques shown in chart below.
- The assembly is completed when the coupling is evenly tightened to the recommended torque. The flanges should touch only at their top edges (Figure 4).

Bolt Size	Ft. Lbs. Torque
5/16	12
1/2	45
5/8	65
3/4	95

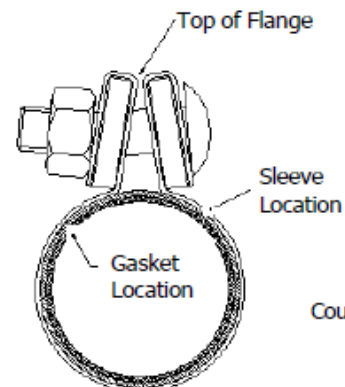

Figure 4
Coupling Fully Tightened

- Where SAE GR 5 5/8" bolts are specified, tighten to 95 ft. lbs. (For couplings with aluminum shell and inner sleeve do not exceed 40 ft. lbs.)



Instalok

IMPORTANT INSTALLATION INSTRUCTIONS

PREPARING FOR INSTALLATION

- Verify tube and Instalok sizes correspond with each other (Figure 1)
- Clean and dry tube OD to ensure it is free of dirt and grease which can cause slippage
- Make sure tube ends are cut square and burr-free to avoid material blockages

ASSEMBLING TUBE & COUPLING

- Twist Instalok onto tube end (Figure 2) until tube is centered in coupling (Figure 3)
 - *NOTE: Twist Instalok or tubing to facilitate installation
- Tighten clamp
- Twist the connecting tube into the Instalok until both ends butt together (Figure 3)
- Tighten remaining clamp

TIGHTENING THE COUPLING

- Tighten the bolts to 50 foot-pounds of torque MAXIMUM (Figure 4)
- Do not over-tighten

Figure 1

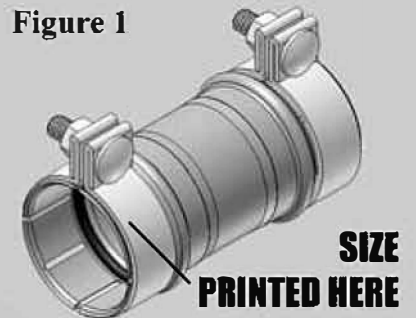

Figure 2

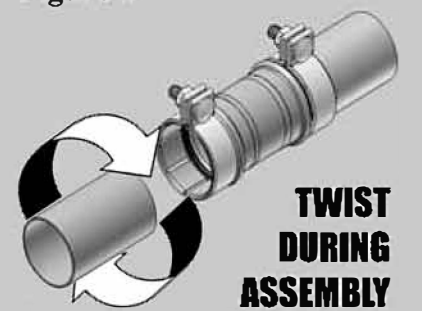

Figure 3

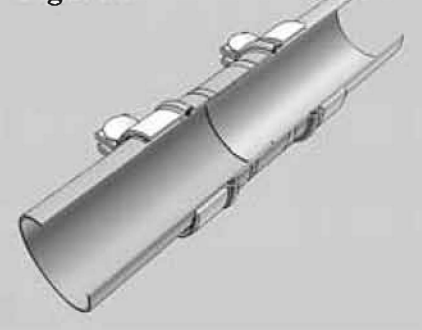
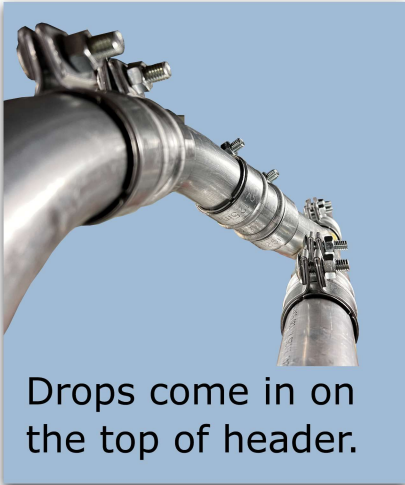

Figure 4





“Top In” Branch Drop



Drops come in on the top of header.

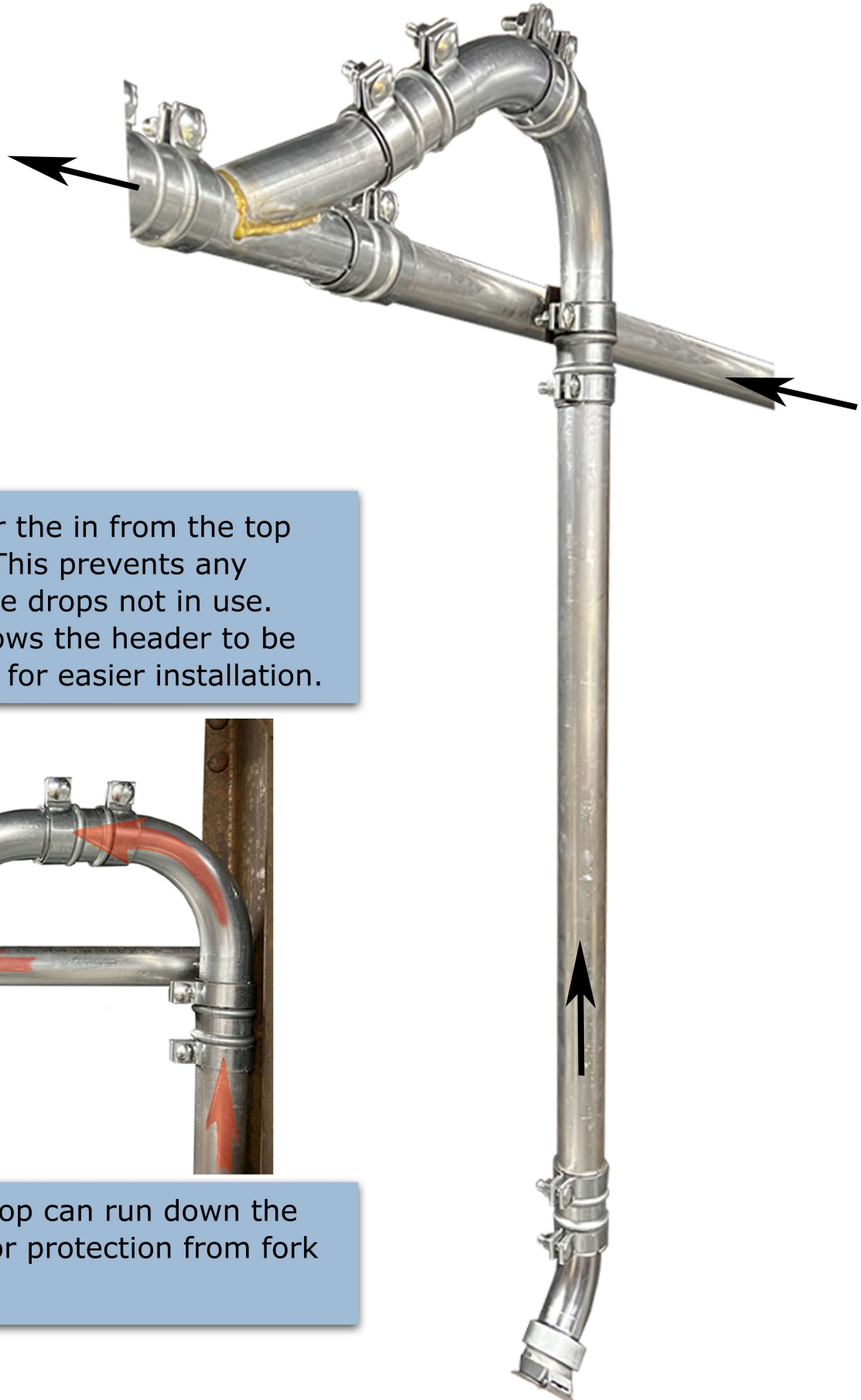

Air and material enter the in from the top of the main header. This prevents any material going into the drops not in use. This configuration allows the header to be adjacent to the drops for easier installation.

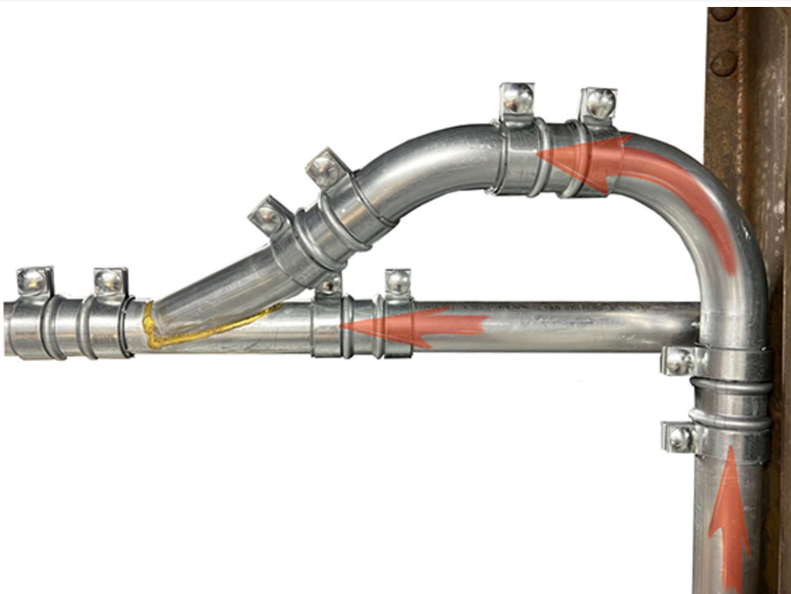

When possible, the drop can run down the inside of an I-Beam for protection from fork lift and other traffic.



“Top In” Branch Drop

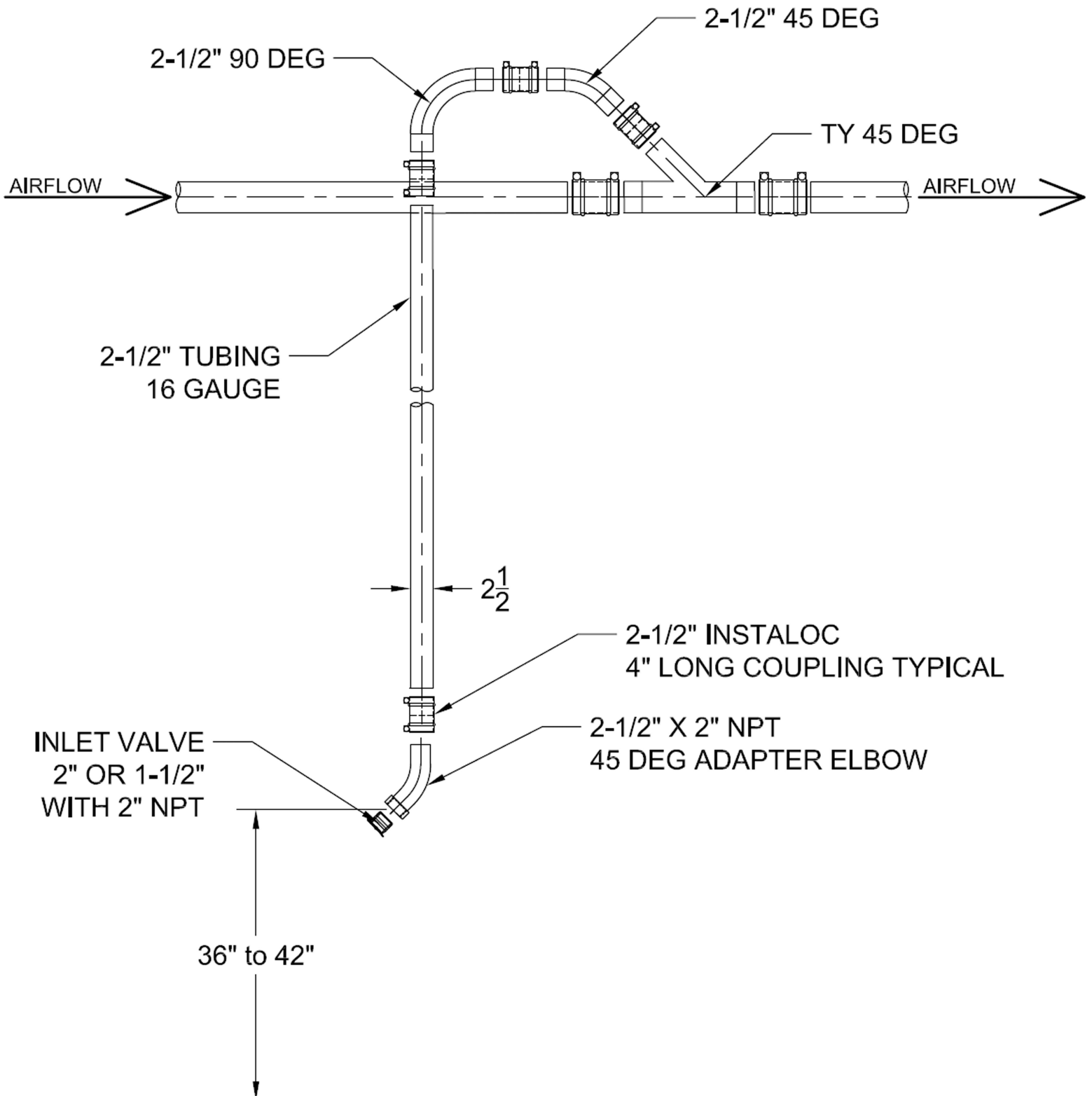



Horizontal Branch Drop



When the top in design will not work, the other acceptable design is come into the header horizontal / parallel to the ground. All branch fittings need to come off the side or top of the main header. Never drop directly off the bottom of the header with a drop.





Horizontal Branch Drop

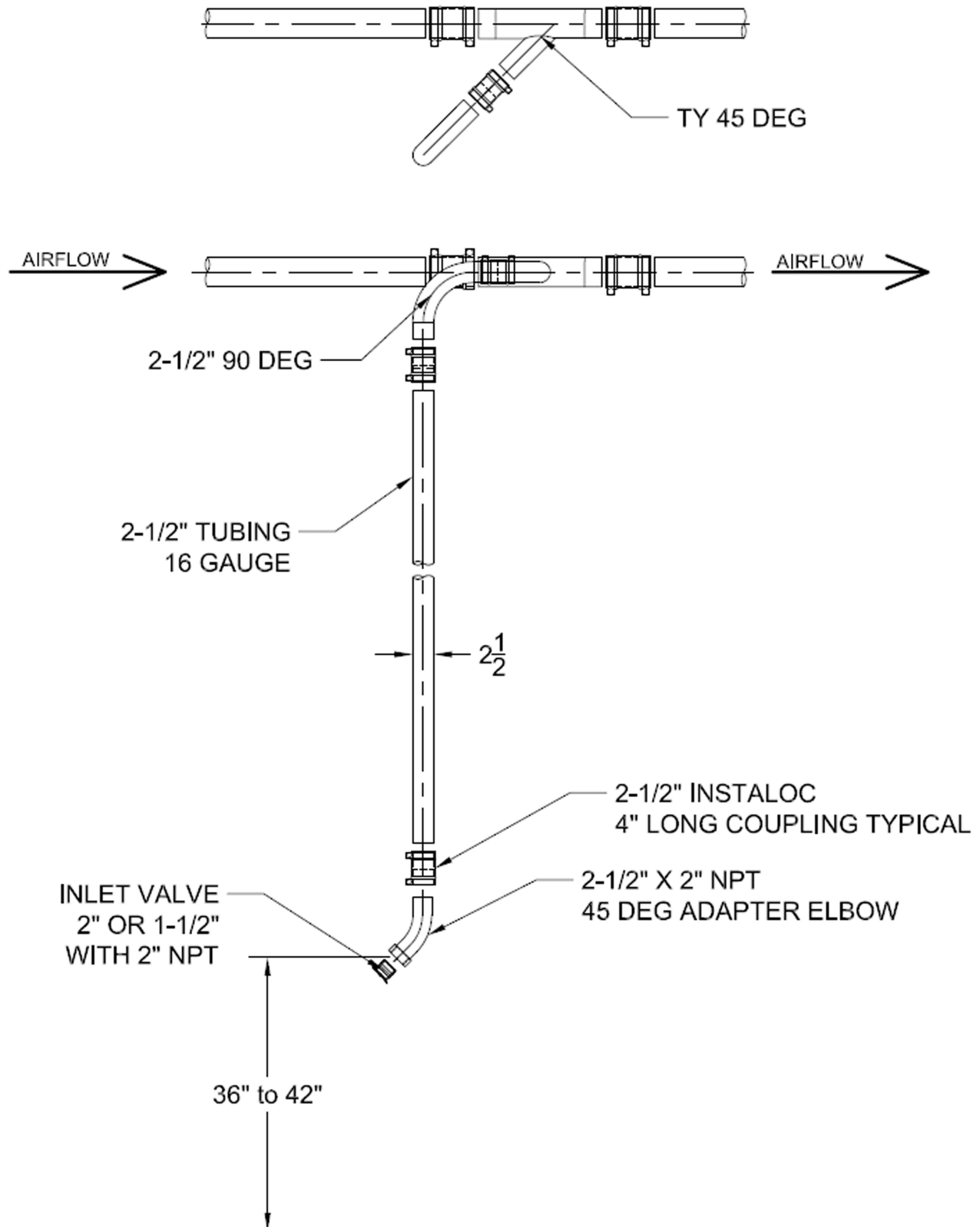



Mezzanine & Upper Floors

A “top in” drop can be used on the lower floor with a 90 degree elbow up to the floor or mezzanine above. This ensures product from either direction cannot drop in the unused area.

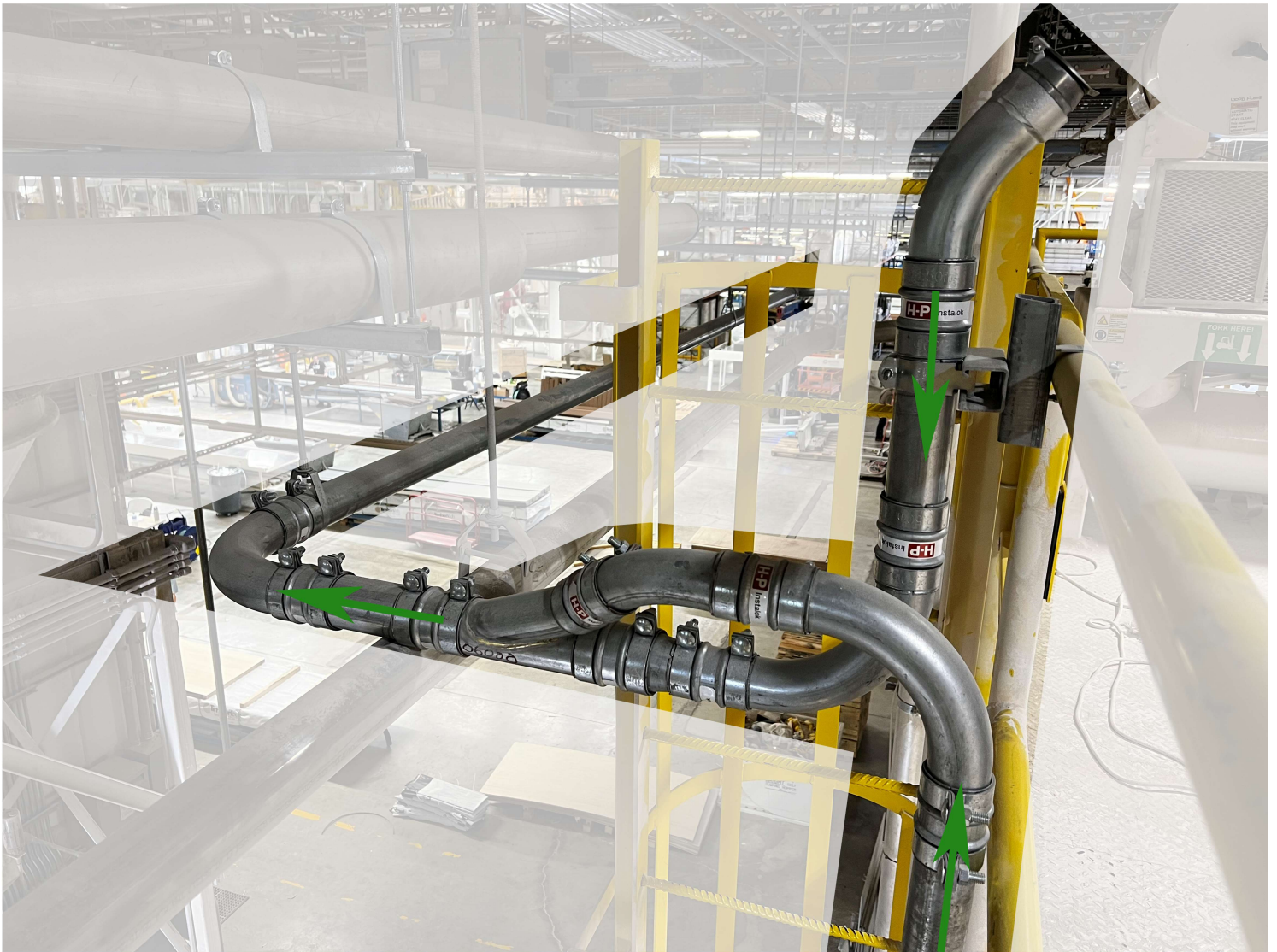

AVOID THIS COMMON ERROR



Avoid any branch that does not come off the side or top of the header. The configuration shown here will plug as material upstream of this drop points falls out and accumulates in the drop not in use.



Label the System

Unless specifically designed for liquids, the systems should only be used for dry dust collection only.

Legends offers labels for the drop as well as hose and tools.



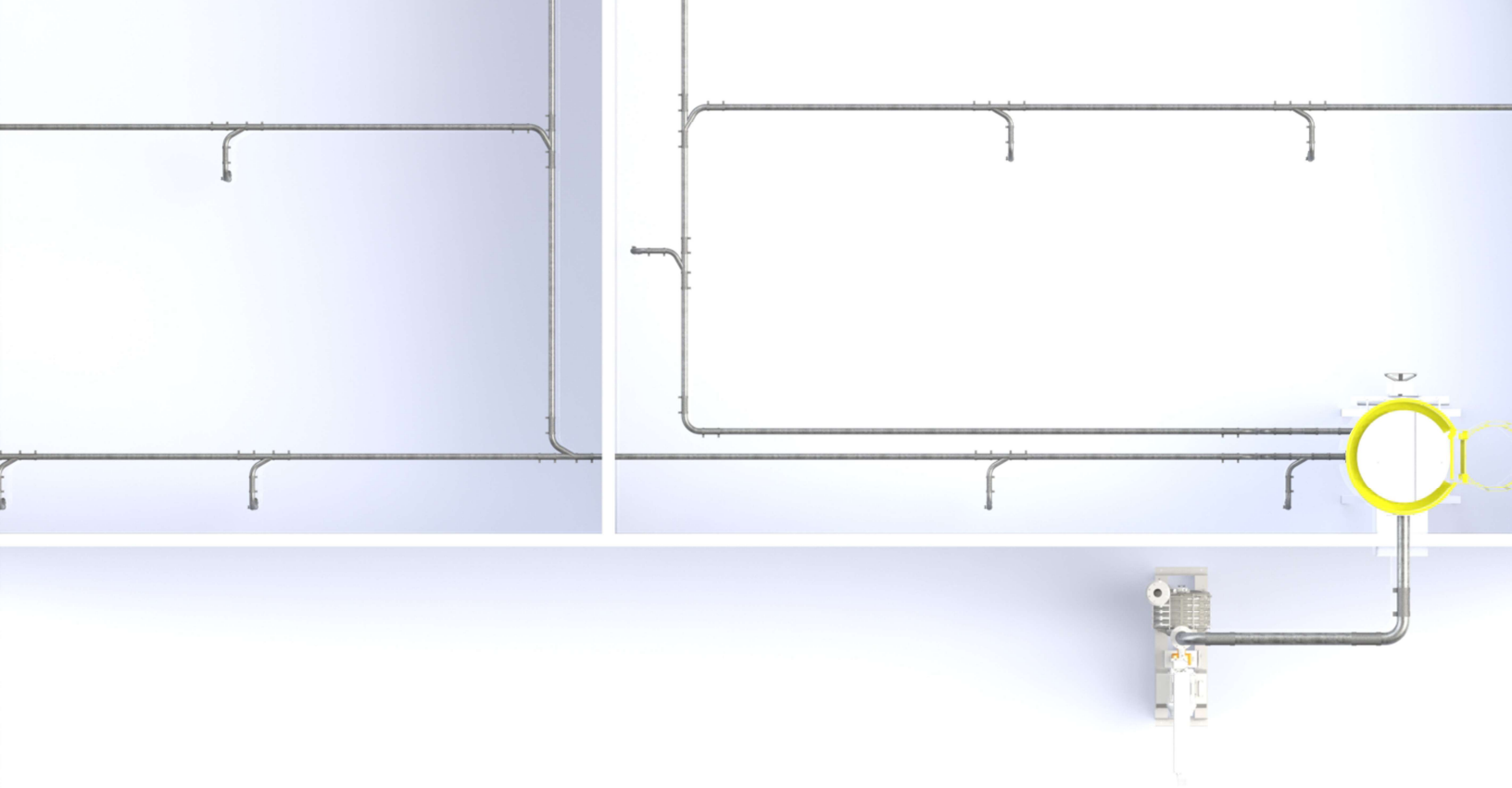

**Example of a typical zoned system.
Each zone terminates at the filter receiver.**

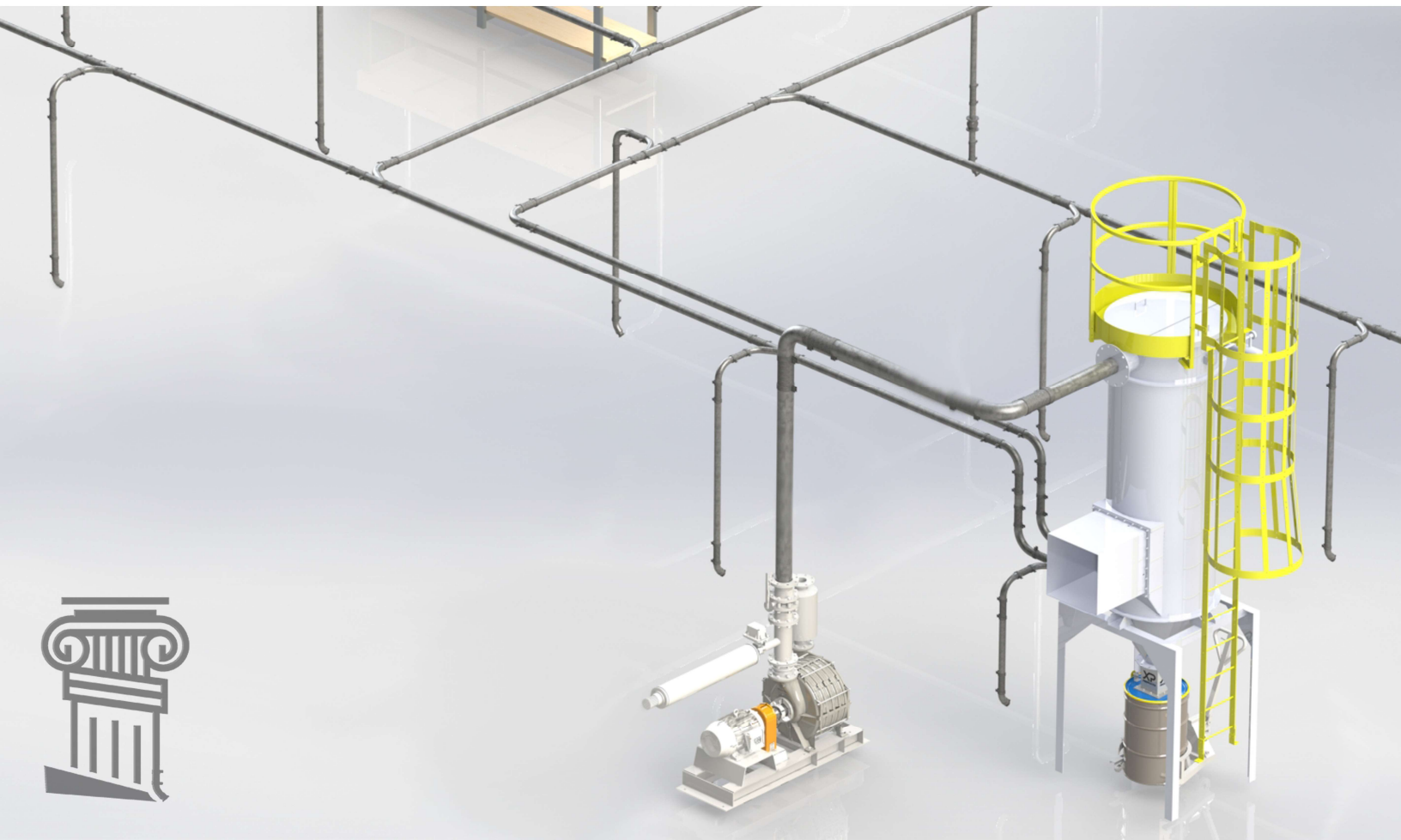

ELBOWS

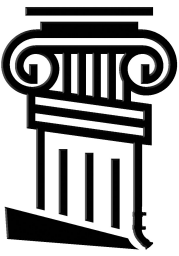

Provide 10 times the tube diameter of straight tube before and after each elbow.

Example. For 3" Tubing, provide 30" before and after each elbow minimum.



Avoid back to back elbows whenever possible.



Avoid tight bend elbows (No Street El)
Centerline bend radius should be a minimum of 2X the diameter.
3X diameter or larger preferred.



Use only Vertical or Horizontal tubing runs for pneumatic conveying and central vacuum systems.

Avoid inclines, they will plug!



Horizontal or Vertical only

TUBING SUPPORT

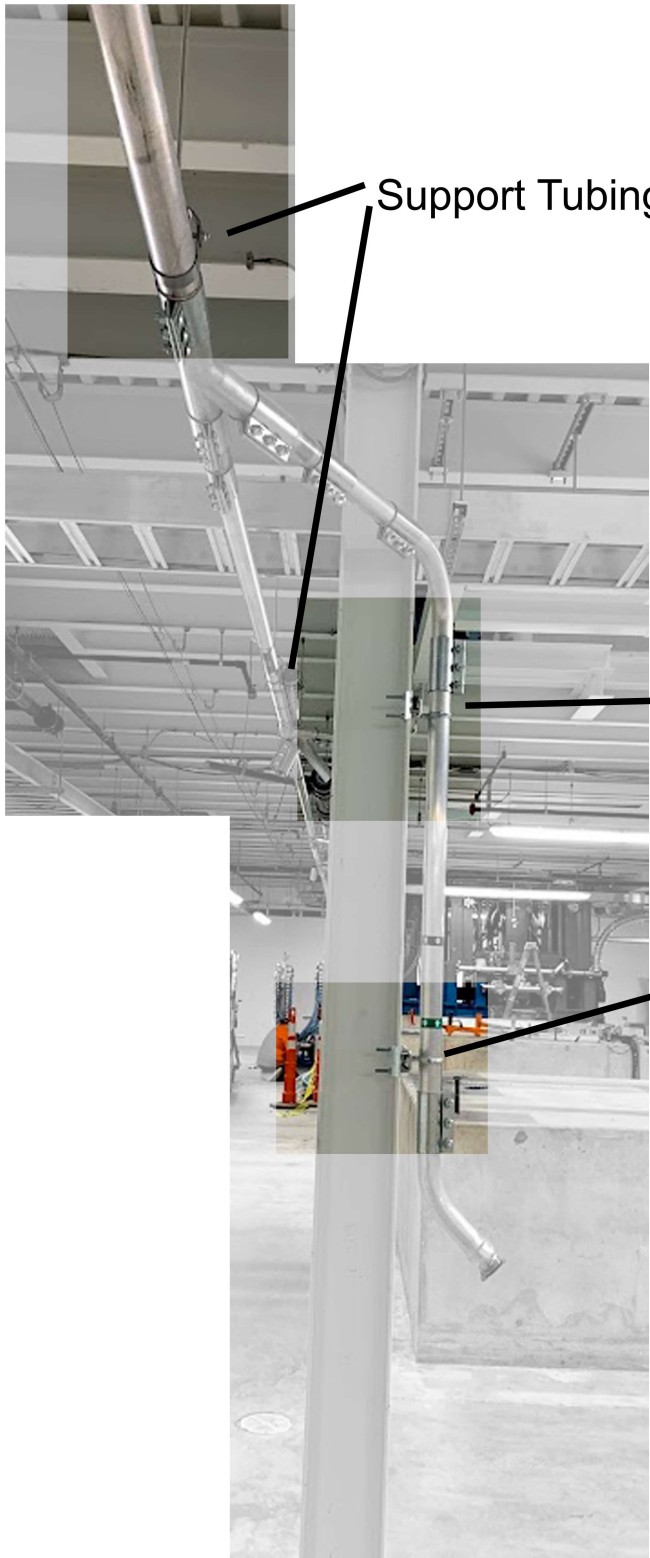

Support Tubing Every 10'

Support at the top of each drop.

Support near inlet valve





LEGENDS EQUIPMENT

Industrial Vacuum System Solutions

213 East 4th Street
Covington, KY 41011

www.LegendsEquipment.com

(513) 337-9745