

Legends Equipment



Round Airlock Multi-Duty (RAM)

- Round flange housing can bolt directly to cone-shaped vessel
- Rotor and housing precision machined for high degree of accuracy and close tolerances
- Incorporates superior TS4 shaft seals on each endplate
- Rugged and durable universal valve



Application

The RAM airlock is a highly universal airlock. Offering rugged service, the RAM is suitable for use in central vacuum systems where a round flanged inlet is preferred.

Equipment

The RAM Airlock includes rotors and housing that are precision machined to obtain a high degree of accuracy and close tolerances and features outboard bearings that require no lubrication. An exclusive TS4 packing gland seal maintains superior performance up to 10 times longer than a typical three-ring seal.

Operating principle

The RAM airlock transfers granular or powdered materials. The RAM is available with either open or closed end rotors. With open end rotors, the product comes in contact with the endplates of the housing. With closed end rotors, the product is confined within the pockets of the rotor.

Specifications

- Rated up to 15 psi pressure differential
- Standard temperature rating is 200°F
- Optional high-temperature rated to 450°F
- Standard cast gray iron (Class 30) housing and end plates with a carbon steel rotor
- Optional stainless steel housing, endplates and rotor
- Rotors available with fixed or adjustable tips
- Rotors available with open or closed ends
- Radius pocket or reduced volume rotor available
- Chrome plated bore and endplates available.
- Optional industrial grade teflon coated rotor.
- Optional food grade silverstone coated rotor.



Dimensions

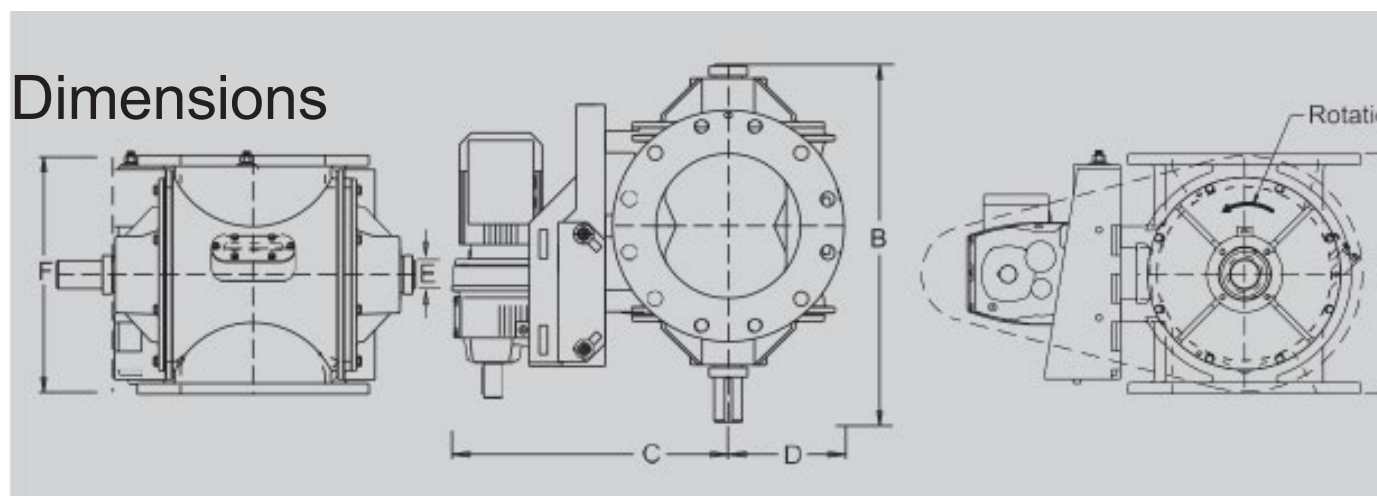

Model	Dimensions						CFR		HP
	A	B	C	D	E	F	OE	CE	
RAM06	12.0" (305 mm)	21.94" (557 mm)	18.75" (476 mm)	8.13" (207 mm)	1.5" (38 mm)	16.25" (413 mm)	0.19	0.17	0.75
RAM08	13.88" (353 mm)	22.88" (581 mm)	18.75" (476 mm)	5.38" (137 mm)	1.5" (38 mm)	16.25" (413 mm)	0.36	0.32	0.75
RAM10	16.5" (419 mm)	25.56" (649 mm)	22.19" (564 mm)	5.38" (137 mm)	1.94" (49 mm)	16.25" (413 mm)	0.7	0.64	1.0
RAM12	21.5" (546 mm)	28.44" (722 mm)	28.75" (730 mm)	10.13" (257 mm)	1.94" (49 mm)	20.25" (514 mm)	1.47	1.36	2.0
RAM14	26.75" (679 mm)	33.31" (846 mm)	28.75" (730 mm)	8.63" (219 mm)	2.19" (56 mm)	17.25" (438 mm)	2.39	2.25	3.0
RAM16	29.13" (740 mm)	38.44" (976 mm)	28.75" (730 mm)	10.13" (257 mm)	2.94" (75 mm)	20.25" (514 mm)	3.11	2.9	3.0

Dimensions are for RAM with a parallel drive package.
Right angle drives are also available.

Model	Wt. (lbs.)	
	Gray Iron	304 S.S.
RAM06	275	285
RAM08	335	345
RAM10	470	485
RAM12	800	835
RAM14	1,345	1,515
RAM16	1,940	1,980