

EXPLOSION PROOF
INDUSTRIAL VACUUM



***DUST REAPER
SERIES 2500XP***

**1001 2ND AVE
DAYTON, KY 41074**

**(513) 337-9745
WWW.LEGENDSEQUIPMENT.COM**

2 HP
POWER

2325 in²
FILTER

11 gal
CAPACITY



Head with double stage filtration system.



BRUSHLESS MOTOR
120 V



M CLASS ANTISTATIC STAR FILTER



(OPTIONAL) FILTER CARTRIDGE HEPA H14

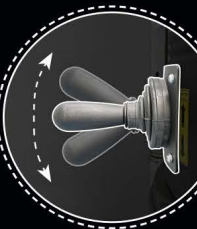

MANUAL SHAKER CLEANING SYSTEM

Smart handle for shaking the filter aggressively to release dust.

INLET WITH DEFLECTOR Ø 2 in



ALL COMPONENTS ARE GROUNDED

STAINLESS STEEL BIN AISI 304

11gal

HIGHLY TRANSPORTABLE

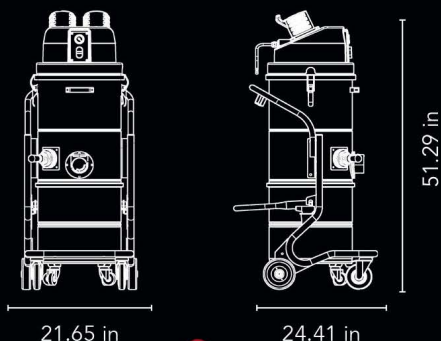

Weight: 99 lbs

DETACHABLE BIN



NFPA 652 Compliance



ATEX Marking:
II 3 D Ex htc III B T140°C Dc

SPEC SHEET

		Units	
Suction type			Brushless motor
Atex Marking			II 3 D Ex htc III B T284°F Dc
Power	HP		2 1~
Voltage Frequency	V Hz		120 50
Maximum vacuum	inH2O		92
Maximum air flow	CFM		129
Inlet	Ø in		2.75
Noise level - (EN ISO 3744)	dB(A)		72
Bin capacity	gal		11
Dimensions	in		21.65 x 24.41
Height	in		51.29
Weight	lb		99
Primary filter			
Type			Star filter
Surface area	in ² in		2325
(Class EN 60335-2-69)			M Class
Media			Antistatic polyester
Filter cleaning			Filter shaker
Absolute filter - Optional			
(Class - EN 1822)	in ²		H14
Media			Fiberglass
In suction			Opt H14
In suction			E10
Engine air inlet cooling	in ²		E10
Outgoing engine air cooling			E10

ACCESSORIES

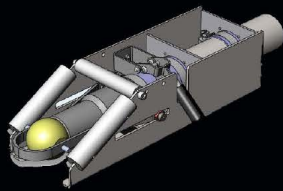

Works with VacTrac System

OPTIONAL



CYCLONIC SEPARATOR



Wet & Dry fixed brush floor tool



Carbon Fiber Overhead Tools

15-F-AC-7181
20-F-AC-7181