



REGEN SOUND ENCLOSURE



CHARACTERISTICS:

- Suitable for outdoor installations.
- Noise reduction 10 dB(A) max.
- With electric axial fan [1] removing heat, generated by the motor and blower [2].
- With air inlet grille for ventilation.[3].
- Aluminum profile frame [4].
- Sandwich panels insulated with mineral wool (sound absorbing / sound insulation) [5].
- Demountable panels with block-panel [6].
- Assembly from top (drop on the blower).
- Floor fixing points available (x2) [7].
- Polyester painted panels RAL 7035.

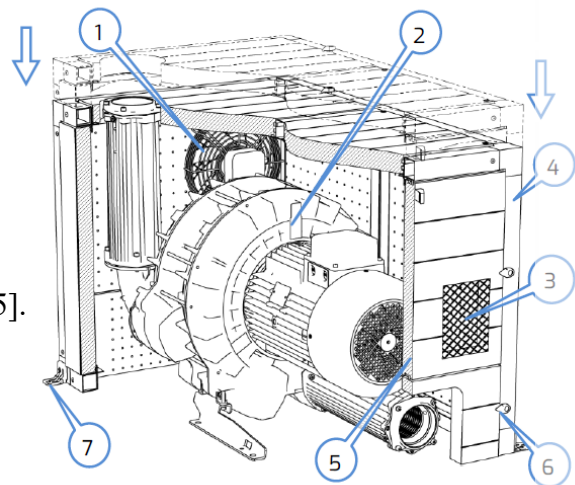

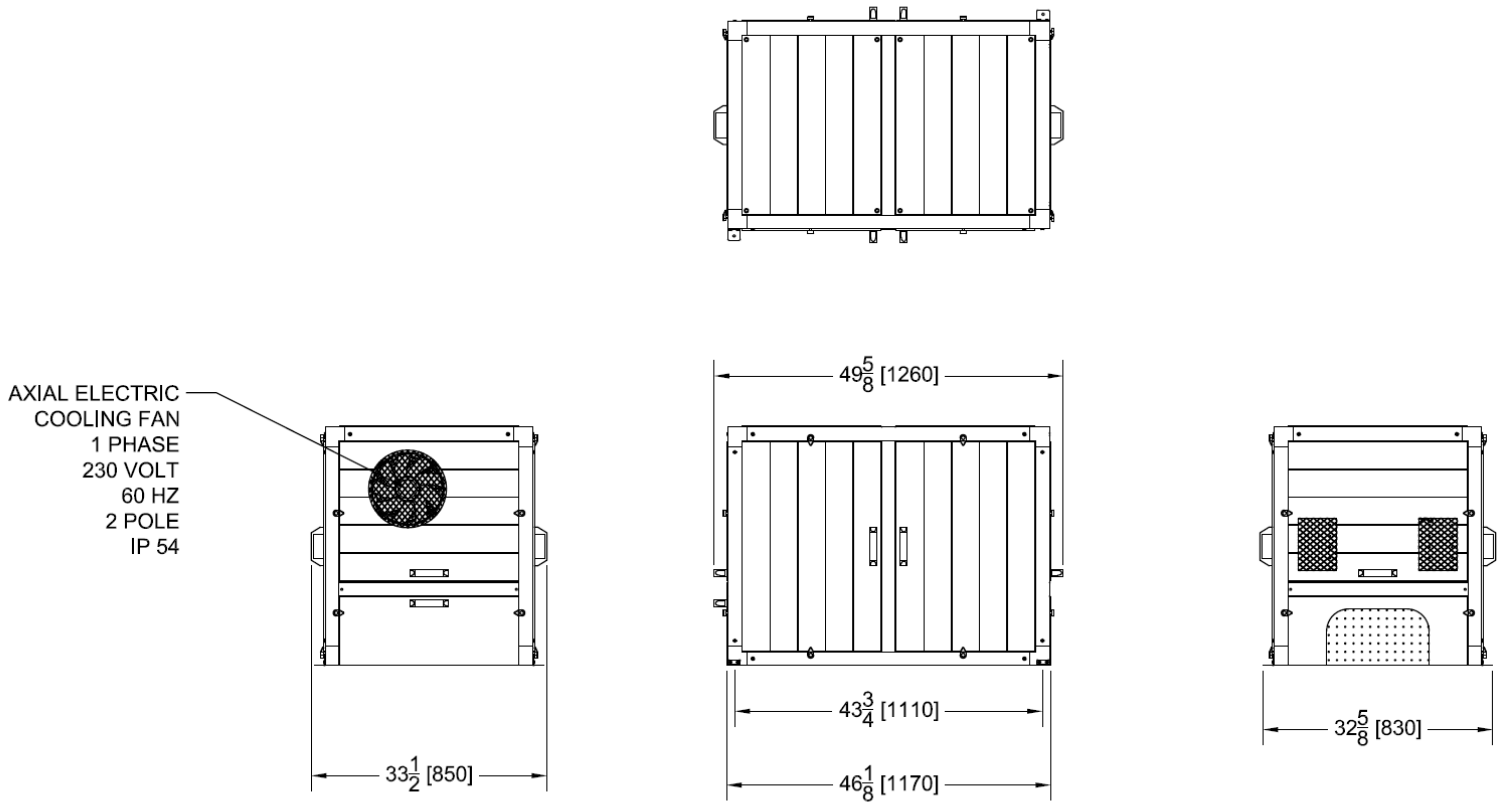

PART NO. CS-SE-2500

WEIGHT: 178 Lbs (81 Kg)

LEGENDS COMPATABLE MODELS

- LL09-MS-15
- LL11-MS-20
- LL12-MS-20
- LL12-MS-25

AXIAL ELECTRIC FAN						
Hz	Volt	Watt	Amp	Phase	Pole	IP
50	230	90	0.42	1	2	54
60		110	0.52			